



ISOMETER® iso175

Insulation monitoring device for unearthed drive systems (IT systems) in road vehicles

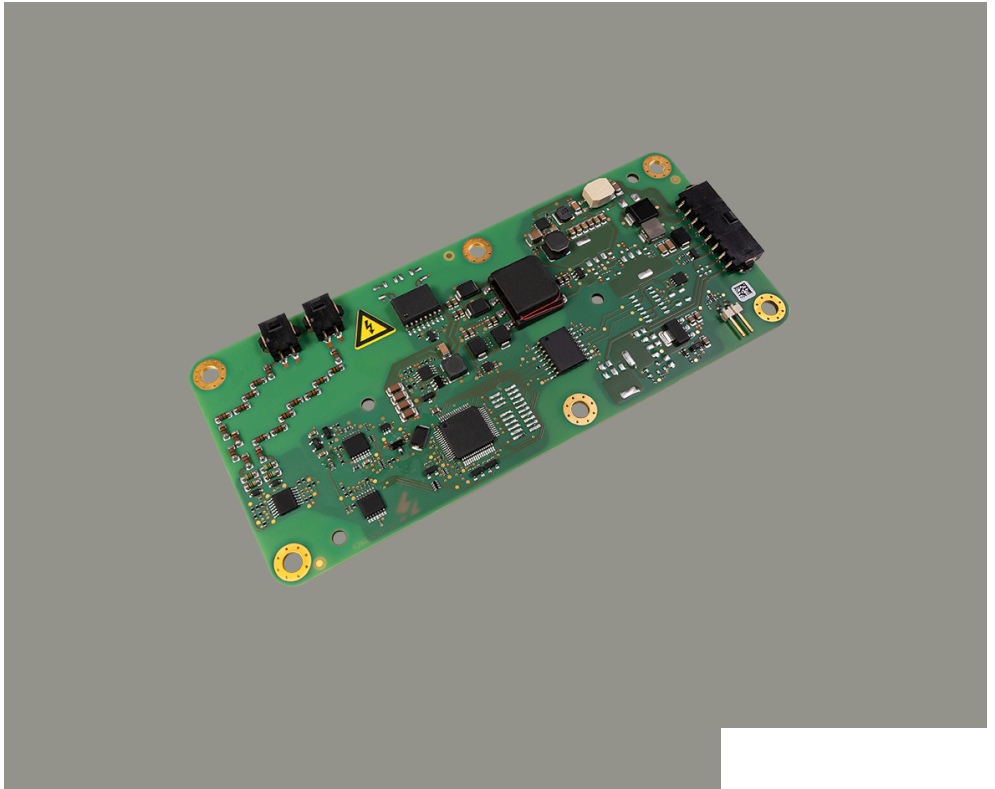

Table of contents

1	General information.....	5
1.1	How to use the manual.....	5
1.2	Indication of important instructions and information.....	5
1.3	Service and Support.....	5
1.4	Training courses and seminars.....	5
1.5	Delivery conditions.....	5
1.6	Inspection, transport and storage.....	6
1.7	Warranty and liability.....	6
1.8	Disposal of Bender devices.....	6
1.9	Safety.....	7
2	List of abbreviations.....	8
3	Device-specific safety instructions.....	9
4	Function.....	11
4.1	Intended use.....	11
4.2	Device features.....	11
4.3	Funktional description.....	11
4.3.1	Insulation resistance measurement.....	11
4.3.2	Measured value quality.....	12
4.3.3	Partial resistances R_{F+} (R_{iso_pos}) and R_{F-} (R_{iso_neg}).....	12
4.3.4	Fast start measurement.....	13
4.4	Self test.....	14
4.4.1	Online self test.....	14
4.4.2	Offline self test.....	15
4.4.3	Offline and communication self test.....	15
4.4.4	Periodical / automatic self test.....	15
4.5	Measurement profiles.....	16
4.5.1	Available measurement profiles.....	16
4.6	Chassis-ground connection.....	17
4.7	Unbalance measurement.....	17
4.8	Measuring the system leakage capacitance.....	18
4.9	Voltage measurement.....	19
4.10	Monitoring functions.....	19
4.10.1	Device error.....	19
4.10.2	HV system.....	19
4.10.3	Status output OK_{HS}	21

4.11	Parameterisation.....	21
4.11.1	Cycle time periodic messages.....	22
4.11.2	CAN-ID.....	22
4.11.3	Product Group Number (PGN).....	22
4.11.4	Baud rate.....	23
4.11.5	Source adress.....	23
4.11.6	Isolnit.....	23
5	Dimensions and mounting.....	24
6	Wiring.....	25
7	Commissioning.....	26
8	Operation.....	27
8.1	R_iso_corrected / R_iso_original.....	27
8.2	Interfaces.....	27
8.2.1	Status output OK _{HS}	27
8.2.2	High-Speed CAN.....	27
8.3	Insulation measurement.....	28
8.4	Checking the connection of the device.....	28
8.5	Profile selection.....	29
9	Maintenance and trouble-shooting.....	30
9.1	Unsafe to start is always active.....	30
9.2	Insulation measurement.....	30
10	Technical data.....	32
10.1	Factory settings.....	32
10.2	Tabular data.....	33
10.3	Standards and approvals.....	36
10.4	Ordering information.....	37
10.5	Revision history.....	38

1 General information

1.1 How to use the manual



ADVICE

This manual is intended for qualified personnel working in electrical engineering and electronics! Part of the device documentation in addition to this manual is the enclosed supplement "Safety instructions for Bender products".



ADVICE

Read the operating manual before mounting, connecting and commissioning the device. Keep the manual within easy reach for future reference.

1.2 Indication of important instructions and information



DANGER

Indicates a high risk of danger that will result in death or serious injury if not avoided.



WARNING

Indicates a medium risk of danger that can lead to death or serious injury if not avoided.



CAUTION

Indicates a low-level risk that can result in minor or moderate injury or damage to property if not avoided.



ADVICE

Indicates important facts that do not result in immediate injuries. They can lead to malfunctions if the device is handled incorrectly.



Information can help to optimise the use of the product.

1.3 Service and Support

Information and contact details about customer service, repair service or field service for Bender devices are available on the following website: <https://www.bender.de/en/service-support>.

1.4 Training courses and seminars

Regular face-to-face or online seminars for customers and other interested parties:

<https://www.bender.de/en/know-how/seminars>

1.5 Delivery conditions

The conditions of sale and delivery set out by Bender GmbH & Co. KG apply. These can be obtained in printed or electronic format.

1.6 Inspection, transport and storage

Check the shipping and device packaging for transport damage and scope of delivery. In the event of complaints, the company must be notified immediately. Please use the contact form at the following address: <https://www.bender.de/en/service-support/take-back-of-old-devices/>.

When storing the devices, observe the information under Environment / EMC in the technical data.

1.7 Warranty and liability

Warranty and liability claims for personal injury and property damage are excluded in the case of:

- improper use of the device
- incorrect mounting, commissioning, operation and maintenance of the device
- Failure to observe the instructions in this operating manual regarding transport, commissioning, operation and maintenance of the device
- unauthorised changes to the device made by parties other than the manufacturer
- non-observance of technical data
- Repairs carried out incorrectly
- the use of accessories or spare parts that are not provided, approved or recommended by the manufacturer
- Catastrophes caused by external influences and force majeure
- Mounting and installation with device combinations not approved or recommended by the manufacturer

This operating manual and the enclosed safety instructions must be observed by all persons working with the device. Furthermore, the rules and regulations that apply for accident prevention at the place of use must be observed.

1.8 Disposal of Bender devices

Abide by the national regulations and laws governing the disposal of this device.



Bender GmbH & Co. KG is registered in the waste from electrical and electronic equipment (WEEE) register under the WEEE number: DE 43 124 402. For more information on the disposal of Bender devices, refer to <https://www.bender.de/en/service-support/take-back-of-old-devices/>

1.9 Safety

If the device is used outside the Federal Republic of Germany, the applicable local standards and regulations must be complied with. In Europe, the European standard EN 50110 applies.



DANGER

Risk of fatal injury due to electric shock!

Touching live parts of the system carries the risk of:

- *Electrocution due to electric shock*
- *Damage to the electrical installation*
- *Destruction of the device*

Before installing the device and before working on its connections, make sure that the installation is de-energised.

Observe the rules for working on electrical systems.

2 List of abbreviations

Abbreviation	Description
CAN	Controller Area Network
HV	High voltage
HS-CAN	High speed CAN
Kl. 15	Terminal 15
Kl. 31	Terminal 31
LV	Low voltage
n.c.	not connected
OK _{HS}	Digital status output (LV pin 8, high-side active)
PGN	Produkt Group Number
SNV	Signal not valid
tbd	to be defined

3 Device-specific safety instructions

**DANGER****High voltage**

Danger to life

The ISOMETER® is galvanically connected to the HV busbar of the vehicle. When it is installed, up to 1000 V are applied to the electronic contacts of the HV connector and the adjacent components. This applies also to the switched-off condition, i. e. when the device is not connected to the 12 V / 24 V voltage supply! The HV connector at the device is therefore furnished with a warning (see below). In addition to the general safety instructions (see chapter "General information", page 5), it must also be ensured that prior to the installation and always when working on the connections of the device (see chapter "Wiring", page 25), the HV connections are safely disconnected and reconnecting them is made impossible for the duration of the work.

The system integrator is responsible for the safety of the entire system. He must ensure that there is sufficient protection against accidental contact according to IEC 61010 during the normal operation of the device.

**WARNING**

Fire hazard

The device is equipped with short-circuit proof inputs. To protect the vehicle's electric system in the event of a fault, customers must provide a corresponding back-up fuse or miniature circuit breaker in the electric circuit of the device's voltage supply.

**ADVICE**

Make sure when integrating the device that the function of the device cannot be impaired by condensation or corrosion.

**ADVICE**

When the energy storage device / battery is charged (e. g. at a charging station), care must be taken that not more than one isometer (e. g. on the vehicle side and on the charging station) is active at the same time in order to prevent devices from influencing each other. These devices can disconnect the connection to chassis ground with a corresponding CAN command.

**ADVICE**

Where IT systems are to be galvanically connected, this connection must be ensured by a low ohmic-resistance connection. Intrinsic diodes, such as body diodes of MOSFET transistors for instance, can adversely affect the insulations resistance measured value so that the specified tolerances can no longer be met.

**ADVICE**

When the periodic self test is deactivated (see chapter "Periodical / automatic self test", page 15), the user must verify that the HV system is connected properly by a different method (e. g. by analysing the high voltage or similar methods).

**ADVICE**

As prerequisite for proper monitoring of the chassis ground connection (see chapter "Online self test", page 14), terminal 31 must be connected to the same potential as LV-pin 3. This connection may not be made directly at the device itself but via chassis ground. Only in this manner can it be ensured that LV-pin 3 is also connected to chassis ground.

**ADVICE**

The ISOMETER® may not be connected to a CAN bus that is critical to safety.

**ADVICE**

In the event of an insulation fault in the monitored system the connection path of the device will get hot. That behaviour is normal and must be taken into account when dismantling the device and searching for faults, especially when ambient temperatures are high.



The internal flash memory guarantees up to 10.000 parameter changes over the entire service life of the device.

4 Function

4.1 Intended use

The ISOMETER® iso175 product line, called ISOMETER® in the following, is designed for installation in correspondingly marked HV-components of road vehicles. There it continuously monitors the insulation resistance of the HV system. Depending on the variant, the device communicates with a higher-level location using different CAN protocols (Bender standard, SAE J1939).



Other installation locations in the vehicle or in industry sectors such as e. g. the shipping, railroad or aerospace industries are considered non-compliant with the intended use.

4.2 Device features

- Suitable for 12 V and 24 V DC systems (supply voltage)
- Insulation monitoring of DC insulation faults for unearthed systems (IT systems)
- Insulation monitoring of AC insulation faults for unearthed systems (IT systems) (from firmware version D720V1.01)
- Continuous insulation resistance measurement $R_{iso_corrected}$ and $R_{iso_original}$
- Response time ≤ 30 s for insulation resistances $\leq 500 \Omega/\text{Volt}$ and system leakage capacitances $\leq 2\mu\text{F}$
- Insulation measurement of larger leakage capacities possible through parameterisation (Profile High Capacity)
- Insulation measurement also when the vehicle's HV electric system is not energised
- integrated self diagnosis (online self test)
- HV connection monitoring (offline self test)
- Continuous monitoring of the earth connection
- Undervoltage detection
- Earth connection can be disconnected (Earthlift)
- Interfaces:
 - Digital output for device error message (OK_{HS})
 - HS-CAN interface with the following protocols
 - Bender-Standard
 - CAN-SAE J1939
 - All outputs short-circuit proof
- Load-dump protection

4.3 Funktional description

4.3.1 Insulation resistance measurement

The overall insulation resistance measurement of an HV system is based on a patented active measuring principle. This method uses a measuring voltage source internal to the device that injects a current into the monitored system, and the resulting voltage drop is measured. This is carried out independently of the voltage of the system to be monitored so that the insulation measurement can also be carried out when the HV system is deenergised.



ADVICE

For a correct insulation resistance measurement, a low-resistance connection between HV+ and HV- is required.

The measuring duration for an individual measurement generally depends on the following factors and it can take up to 60 seconds:

- Overall insulation resistance of the HV system
- System leakage capacitance (Y capacitance)
- Measuring profile used (device parameter)

The present duration of an individual insulation measurement is output by the measured value *Isolation: Time_elapsed_since_last_measurement*. At the beginning of each new insulation measurement this value is automatically reset to 0 s.

Due to the then following internal statistical filtering and averaging of the individual measured values, the insulation resistance measured value is only available at the device interface with a delay (after up to 12 individual measurements).

When the fast start measurement is activated (Power-On profile "Standard with fast startup" or "High Capacity with fast startup"), the insulation resistance measured values ($R_{iso_original}$, $R_{iso_corrected}$ and R_{iso_neg} , R_{iso_pos}) satisfy the specified tolerance as soon as the status signals $R_{iso_status} = 0xFE$.

When the fast start measurement is deactivated (Power-On profile "Standard", "High Capacity", "Disturbed", "Service"), the specified tolerance is met only after 12 individual measured values have been obtained in the status $R_{iso_status} = 0xFE$.

i For a rough estimate of the duration of an individual measurement, the following approximation formula can be used:

$$t \sim 5 * R_i // R_{iso} * C_e$$

An insulation resistance $R_{iso_corrected}$ is made available at the interface, and from which the currently valid "tolerance value" (set tolerance percentage times measured value) is subtracted. This ensures that this measured value never exceeds the actually present insulation resistance. The following example serves to illustrate this device function:

$$R_f = 1 \text{ M}\Omega, R_{iso_original} \text{ (measured)} = \text{e. g. } 1.05 \text{ M}\Omega \rightarrow \text{tolerance } \pm 12 \%$$

$$R_{iso_corrected} = 1.05 \text{ M}\Omega - 1.05 \text{ M}\Omega * 0.12 = 924 \text{ k}\Omega$$

4.3.2 Measured value quality

For every insulation resistance value ($R_{iso_original} / R_{iso_corrected}$) there is a quality information (*Isolation: Quality*) which reflects the reliability of the measured insulation resistance value.

In a stable HV system without voltage fluctuations the quality is always between 90 % and 100 %.

When the HV voltage is instable, the currently performed measurement may be aborted. The obtained measured values are characterised internally as invalid and are discarded by the statistical filtering. In the event that such results occur too often over a short period of time, the statistical averaging is impaired, which is signalled by the reduction in the quality value.

4.3.3 Partial resistances R_{F+} (R_{iso_pos}) and R_{F-} (R_{iso_neg})

The overall insulation resistance corresponds to the parallel connection of the two partial resistances of R_{F+} and R_{F-} in each case to earth.

The two partial resistances R_{iso_pos} (R_{F+}) and R_{iso_neg} (R_{F-}) are calculated from the overall insulation resistance using the residual voltage (voltage difference U_{RF+} and U_{RF-}). For this an HV voltage of at least DC 100 V is needed, if not, the two partial resistances are output as SNV.

Wiring example

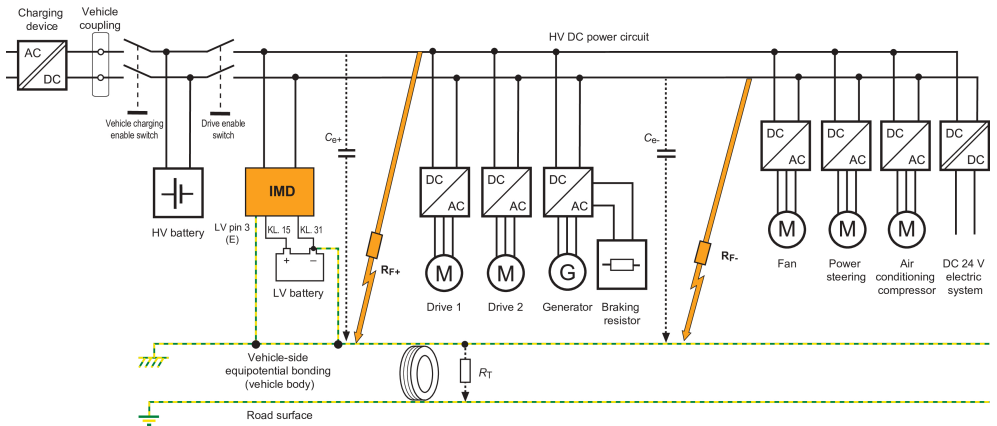

4.3.4 Fast start measurement

The ISOMETER® includes a fast start measurement that is dependent on the selected profile. After a restart this provides the user with a quick overview over the insulation status of the HV system before the first, complete measurement has been carried out. The following profiles support this function:

- 1: Standard with fast startup (default)
- 3: High Capacity (capacitance) with fast startup

What is important here is that this function is only active during the device status $R_{iso_status} = 0xFC$ (estimated insulation value during startup). During this device status the user can also evaluate the status information: *Warnings_and_Alarms, bit 9* (Unsafe to Start). As soon as this signal displays the value *false*, the insulation resistance of the connected system is at least twice the configured insulation parameter: *Isolation_Threshold_Warning*.

During this device status, interim values (“estimated” values) of the insulation resistance with a period duration of 200 ms are calculated. Characteristic for the behaviour of these interim values over time is that in a stable HV system (no voltage fluctuation) the measured value increases steadily until the complete insulation measured value is available. To facilitate evaluating the reliability of the calculated interim values (estimation), every estimate is furnished with the corresponding quality information (*Isolation: Quality*). Both measured values (*Estimated, Isolation: Quality*) are already evaluated internally, and the result is output as the signal *Status: Warnings_and_Alarms, bit 9*.

The evaluation of the two measured values is based on the following:

Condition 1:

The currently calculated interim value (estimated value) must correspond to at least twice the alarm-warning threshold (*Isolation_Threshold_Warning*).

Condition 2:

The quality of the measured value must be at least 80%.

When both conditions are met, the HV system is considered safe and the signal status: *Warnings_and_Alarms, bit 9 = false* is set.

However, the interim values (estimated values) are only calculated when the following conditions have been met by the HV system:

Condition 1:

The voltage of the HV system must be stable for at least 200 ms within the first 3 s after the insulation measurement has been started, i. e. the voltage may not change by more than 0.4 V / 200 ms (default value). This threshold value can be changed by the user, if necessary (*Isolation: Pre_estimation_max_difference*).

Condition 2:

The difference of the two voltages *HV_neg_to_Earth* and *HV_pos_to_Earth* may not exceed a threshold value of 100 V (default value). This threshold value can be changed correspondingly by the user, if necessary (*Threshold_first_reference_estimation*).

As soon as both conditions are met, calculation of the interim (“estimated”) values is started. In the event that these two conditions are not yet fulfilled after maximally 3 s, the fast start measurement is aborted and interim values (“Estimateds”) are no longer calculated. As long as the device status is *R_iso_status = 0xFC*, the *signal Status: Warnings_and_Alarms, bit 9* no longer changes its value (true). In this case users need to wait for the first measured value (*Device status R_iso_status = 0xFE*) so that they can evaluate the insulation status of the HV system.

i *The signal *Isolation: Measurement_Counter* can be used to determine whether a fast start measurement is still active or whether it has been aborted. As long as the measured value counter is increased with a frequency of 5 Hz, the fast start measurement is active.*

4.4 Self test

4.4.1 Online self test

The online self test includes all device-internal test functions that are performed automatically and periodically in the background and do not influence an active insulation resistance measurement. The internal test functions includes monitoring the measurement voltage source (MVS), which ensures that the voltage required for the insulation measurement remains within the permissible tolerance range. If one or more test functions fail, a device error is triggered (*Device Status: Device_Error, bit 0*).

When such an error occurs, the technical support (see chapter “Service and Support”, page 5) shall be contacted.

In addition to the device-internal test functions, the electrical connection of connector LV pin 3 (E) to chassis ground is checked. The result of this test can be evaluated by reading out the signal *Status: Warnings_and_Alarms, bit 3*. In contrast to the online test functions described above, a fault of the chassis-ground connection does not result in a device error.



ADVICE

For the function which tests the chassis-ground connection to work properly, the LV pin 1 connector must also be connected to the chassis ground potential. We recommend making this connection not directly at the device but via the chassis-ground potential. This ensures that the entire connection line from LV-pin 3 to chassis ground is monitored.

4.4.2 Offline self test¹

The offline self test checks the following device functions:

- Electrical connection from connector HV+ to connection cable HV+ (L+)
- Electrical connection from connector HV- to connection cable HV- (L-)



ADVICE

During the test only the electrical connection is checked, the polarity of the connection, however, is not checked.

This offline self test can be carried out at any time during the operating mode "normal insulation measurement" ($R_{iso_status} = 0xFE$) by sending the control command *Self test: Trigger_self_test* with the content (Data1) = 1. Here care must be taken that the offline self test is carried out only when the connection switch to chassis ground (earth disconnecter) is closed (*Signal Earthlift: Status = 0x00*). The self test takes ≤ 1 s. In case the connection switch first needs to be closed, an additional delay time of maximal 1 s must be taken into account.

Reading out the signal *Status: Device_Activity* permits verifying whether the offline self test is still ongoing or whether it was fully completed. As long as the test is ongoing, this command is answered with the value (Data1) = 2. The results of the offline self test are obtained by reading out the signal *Status: Warnings_and_Alarms*, bits 1 and 2).

Bit 1: true = HV+ connection failure

Bit 2: true = HV- connection failure

Please note that when there is a faulty earth connection, also the two connection tests to HV+ and HV- will signal an error, because for these tests a connection to chassis ground is indispensable.

4.4.3 Offline and communication self test

This test function can be started any time during the operating mode "normal insulation measurement" ($R_{iso_status} = 0xFE$) by sending the control command *Self test: Trigger_self_test* with the content (Data1) = 2. In addition to the described offline self test, this function also performs a test of the status output OK_{HS} (LV pin 8). For this, the status output is switched to low for approx. 5 s during the self test. During this time, the alarm "Status: Warnings_and_Alarms, Bit 0" is also active (true).

4.4.4 Periodical / automatic self test

The ISOMETER® offers users the possibility of carrying out an automated offline self test at periodic intervals. By programming the parameters *Self test: Period*, they can set the period duration as needed in 10 s increments. Please note that the first test is only started when the device is in the operating mode "normal insulation measurement" ($R_{iso_status} = 0xFE$) and the configured time interval has passed.



ADVICE

The first automated self test is performed 1 h after switching on the supply voltage. Should the continuous operating time of the unit be < 1 h, it is recommended to adjust the period accordingly, so that the connection check is carried out appropriate. In the event that the periodical self test is deactivated (period duration = 0), the user is responsible for the appropriate connection to the HV system.

¹ This test only works in a DC system.

4.5 Measurement profiles

The ISOMETER® offers users different measurement profiles which they can use to better adapt their device to the respective HV system. This adaptation can be performed in 2 ways:

Temporarily: If sudden disturbances occur in an HV system, e. g. significant HV voltage fluctuations, users can change the active profile in the operating mode “normal insulation measurement” at any time (*Isolation: ActiveProfile*). This change will remain active until the device is restarted. After a restart the “Power-On” profile (*Isolation: Power-On_Profile*) is set as the active profile.

Permanently: The device offers users the possibility of changing the measurement profile to be used permanently so that it remains active even after a restart of the device. To this end the parameters *Isolation: Power-On_Profile* must be changed to the desired measurement profile.

4.5.1 Available measurement profiles

Standard (profile 2)

- Suitable for system leakage capacitances $\leq 5 \mu\text{F}$
- Internal digital 1 Hz filter
- Internal statistical filtering of several individual measured values
- Maximum measuring time for one individual measurement $\leq 30 \text{ s}$

Standard with fast startup (profile 1, default value)

- Same as the properties of the "Standard" profile + fast start measurement active

High Capacity (capacitance) (profile 4)

- Suitable for system leakage capacitances $\leq 10 \mu\text{F}$
- Internal digital 1 Hz filter
- Internal statistical filtering of several individual measured values
- Maximum measuring time for one individual measurement $\leq 60 \text{ s}$

High Capacity (capacitance) with fast startup (profile 3)

- Same as the properties of the High Capacity profile + fast start measurement active

Disturbed (profile 5)

- Suitable for HV systems with voltage changes $< 1 \text{ Hz}$
- Internal digital 0.1 Hz filter
- Internal statistical filtering of several individual measured values
- Maximum measuring time for one individual measurement $\leq 60 \text{ s}$

Service (profile 6)

- Suitable for a fast insulation measurement without internal statistical filtering (service function, not suitable or recommended for the operating mode “normal insulation measurement”)
- Suitable for system leakage capacitances $\leq 10 \mu\text{F}$
- Internal digital 1 Hz filter
- Maximum measuring time for one individual measurement $\leq 60 \text{ s}$

Custom profile (profile 0)

- Reserved: This profile is reserved for customer-specific adaptations to a specific HV system, for which the available standard profiles do not supply the measurement results desired in terms of measured value tolerance. For further information, see customer configuration under “Ordering information”, page 37.

4.6 Chassis-ground connection

The device can use a CAN command (*Earthlift: Status*) to separate the chassis-ground connection.

The chassis-ground connection must always be disconnected when a further isometer monitors the HV system. If the chassis-ground connection were not separated, a further isometer would measure also the internal resistance of the ISOMETER® and hence output a false value for the insulation resistance of the HV system (parallel connection of the ISOMETER® internal resistance and the insulation resistance of the HV system). Also, connected isometers can disturb each other (voltage of the measuring pulse). The result of such a disturbance may be considerable deviations in the measured values.

4.7 Unbalance measurement

i The "Unbalance measurement" function (*Unbalance: Measured_Value*) is only specified for DC systems. When connected to an AC system, the unbalance measurement value is not calculated correctly and can lead to incorrect diagnoses. An evaluation of the insulation status via the unbalance is not permitted in AC operating mode.

To evaluate the distribution (symmetrical or asymmetrical) of the overall insulation resistance of an HV system, users can analyse the following measured value: *Unbalance: Measured_Value*. This measured value indicates the percentage distribution of the overall insulation value. The prerequisite for calculating this measured value is an HV voltage of at least DC 100 V and an insulation resistance ≤ 5 M Ω . If at least one of these prerequisites is not met, the measured value is set to invalid (SNV).

When the measured value is < 50 %, the lower insulation resistance is on HV+ to chassis ground, with a measured value that is > 50 %, it is correspondingly on HV- to chassis ground.

As soon as a new measured value is available, the corresponding measured value counter increases accordingly (*Unbalance: Measurement_Counter*). When the measured value exceeds or is below a threshold that can be configured by the user (*Unbalance: Threshold*) an alarm can be triggered in addition (*Status: Warnings_and_Alarms*).

When the threshold + 5 % hysteresis exceeds, the alarm bit is automatically deleted again (*Condition: Self-holding Alarm: Activation = 0xFC*).

For this the following conditions must be met:

- HV voltage \geq DC 100 V
- *R_iso_status* = "Normal Measure" (0xFE)
- Earth disconnector closed



ADVICE

With an unbalance threshold value of 45 %, it should be noted that due to the hysteresis of 5 % and the tolerance of the voltage measurement, the device may not exit the alarm state under unfavourable circumstances (max. tolerances), even if the unbalance error no longer exists. In this case, the device must be restarted.

Procedure for a permanent unbalance alarm:

- Switch off the vehicle system safely.
- Eliminate the cause of the fault in the HV system.
- Wait at least 120 seconds before restarting the ISOMETER®.

Only after this waiting time will the internal fault memory for unbalance monitoring be reliably deleted.

Examples

Example 1:

Unbalance Threshold = 40 [%]

HV voltage = DC 150 V

$R_{iso_neg} = 1\text{ M}\Omega$

$R_{iso_neg} = 1\text{ M}\Omega$

$1\text{ M}\Omega \parallel 1\text{ M}\Omega = 500\text{ k}\Omega < 5\text{ M}\Omega$

In this case the measured value "Unbalance" is 50 [%].

Example 2:

Unbalance Threshold = 40 [%]

HV voltage = DC 150 V

$R_{iso_neg} = 780\text{ k}\Omega$

$R_{iso_pos} = 1220\text{ k}\Omega$

$780\text{ k}\Omega \parallel 1220\text{ k}\Omega = 590\text{ k}\Omega < 5\text{ M}\Omega$

In this case the measured value "Unbalance" is 61 [%].

Evaluation of the unbalance-alarm status: $100\% - 61\% = 39\%$ → the value is below the threshold value "Unbalance Threshold" and an "Unbalance Alarm" is triggered.

Example 3:

Unbalance Threshold = 40 [%]

HV voltage = DC 150 V

$R_{iso_neg} = 1220\text{ k}\Omega$

$R_{iso_pos} = 780\text{ k}\Omega$

$780\text{ k}\Omega \parallel 1220\text{ k}\Omega = 590\text{ k}\Omega < 5\text{ M}\Omega$

In this case the measured value "Unbalance" is 39 [%].

Evaluation of the unbalance-alarm status: 39% → the value falls hence short of the threshold value "Unbalance Threshold" and an "Unbalance Alarm" is triggered.

The hysteresis for resetting the alarm status is 5 %, i. e. when the measured value is \geq unbalance threshold + 5 %, the alarm is reset.



ADVICE

By coupling the ISOMETER® to the system to be monitored, a parallel connection is established between a coupling path (2,4 MΩ) and the existing R_{iso_pos} and R_{iso_neg} , which also influences the asymmetry of the partial voltages. The ISOMETER® calculates this influence internally so that the measured value only refers to the existing insulation resistances.

4.8 Measuring the system leakage capacitance

The ISOMETER® is furnished with a measuring function that serves to determine the overall system leakage capacitance of the HV system ("Capacity": *Measured_value*). Among other things this measured value serves to select a suitable measurement profile for the insulation measurement (*Standard / High Capacity*).

As soon as a new measured value is available, the corresponding measured value counter is increased accordingly (*Capacity: Measurement_Counter*).

4.9 Voltage measurement

The following voltages are measured

- HV-system voltage (*Voltage: HV_System*)
- HV+ to chassis_ground (*Voltage: HV_pos_to_Earth*)
- HV- to chassis_ground (*Voltage: HV_neg_to_Earth*)

Depending on the specific configuration, the voltage measured values can contain the following voltage components:

- AC (*Voltage: Mode = 0xFD*)
- DC (*Voltage: Mode = 0xFE*)

When operating the ISOMETER® on an AC system, the *Voltage: Mode* parameter must be set to AC (0xFD) to ensure that the voltage measurement functions correctly. If the default value DC (0xFE) is retained, the displayed HV voltage is not valid and may lead to incorrect interpretations.

The described measured values are always updated together, and the corresponding measured value counter is increased accordingly (*Voltage: Measurement_Counter*).

In addition, the ISOMETER® is furnished with a configurable undervoltage detection (*Voltage: Threshold_Undervoltage*), which triggers a corresponding alarm when the value falls below the programmed threshold value (*Status: Warnings_and_Alarms*).

4.10 Monitoring functions

4.10.1 Device error

As a general rule, a device error alarm (*Status: Warnings_and_Alarms*, bit 0) is only active as long as the condition for signalling the alarm is met.

4.10.2 HV system

The ISOMETER® provides users with various monitoring functions regarding the condition of the HV system so that they can respond immediately to possible critical situations.

The device also offers the possibility of retaining an alarm event until a user resets it manually. In this manner users can record also very brief alarm events and evaluate them at a later time.

To this end the parameters *Self-holding Alarm: Activation= 0xFD* must be set. By sending the command *Self-holding Iso-Alarm = 0x01* users can reset all active alarm bits, provided that the corresponding alarm condition is no longer met.

HV+ to chassis-ground error

The ISOMETER® offers the possibility of checking the electrical connection between HV+ and chassis ground. For this purpose the offline self test must be carried out (see chapter "Offline self test", page 15). A faulty connection is indicated with the signal *Status: Warnings_and_Alarms*, bit 1.



ADVICE

Prerequisite for proper functioning of this check is a DC system and a system leakage capacitance ≥ 100 nF between HV+ and chassis ground.

HV- to chassis-ground error

The ISOMETER® offers the possibility of checking the electrical connection between HV- and chassis ground. For this purpose the offline self test must be carried out (see chapter “Offline self test”, page 15). A faulty connection is indicated with the signal *Status: Warnings_and_Alarms, bit 2*.



ADVICE

Prerequisite for proper functioning of this check is a DC system and a system leakage capacitance ≥ 100 nF between HV- and chassis ground.

Chassis-ground connection faults

The ISOMETER® continuously monitors the connection between LV pin 3 (earth connection) and chassis ground (see chapter “Online self test”, page 14). A faulty connection is indicated with the signal *Status: Warnings_and_Alarms, bit 3*.



ADVICE

Prerequisite for proper functioning of this check is that the LV pin 3 connection is on the same potential as terminal 31. Making this connection at chassis ground is recommended. This ensures that LV pin 3 is connected not only to terminal 31 but actually to chassis ground, which is the precondition for a functioning insulation measurement. For a correct connection, the ohmic resistance between LV pin 3 and chassis ground must be ≤ 2 k Ω . With an ohmic resistance ≥ 4 k Ω a connection fault is definitely recognised, and the corresponding alarm bit is set.

Insulation resistance fault (alarm)

The ISOMETER® signals a fault of the insulation resistance (*Status: Warnings_and_Alarms, bit 4*), when the measured value falls short of the threshold value *Isolation: Threshold_Error*. The alarm bit is reset provided that the currently measured insulation resistance is \geq (*Isolation: Threshold_Error* + 25 % hysteresis).

Insulation resistance warning (prewarning)

The ISOMETER® signals a fault of the insulation resistance (*Status: Warnings_and_Alarms, bit 5*), when the measured value falls short of the threshold value *Isolation: Threshold_Warning*. The alarm bit is reset provided that the currently measured insulation resistance is \geq (*Isolation: Threshold_Warning* + 25 % hysteresis).



ADVICE

*The two parameters *Isolation: Threshold_Error* and *Isolation: Threshold_Warning* are cross-checked for plausibility. When the parameter *Isolation: Threshold_Error* $>$ *Isolation: Threshold_Warning* a *Device_Error_Alarm* is triggered.*

Insulation resistance measured value no longer up to date

The ISOMETER® offers the possibility of monitoring automatically whether the insulation resistance measured value is updated within a defined time period (parameter *Isolation: Threshold_Timeout_Measurement*). If the measured value has not been updated within the defined time period, the corresponding alarm bit (*Status: Warnings_and_Alarms, bit 6*) is set. As soon as the insulation resistance measured value has been updated, a possibly active alarm is reset automatically (prerequisite: *Self-holding Alarm: Activation = 0xFC*).

**ADVICE**

For proper functioning of this feature, the maximum measuring time for an individual measurement (dependent on the respective profile) must be selected for the *Threshold_Timeout_Measurement* ≤, since after the maximum measuring time has expired an ongoing measurement is aborted and a new measurement is automatically started (see chapter "Measurement profiles", page 16).

HV voltage unbalance faults

When the function (*Unbalance: Threshold > 0*) is activated, the ISOMETER® monitors the two partial voltages HV+ and HV-, in each case against chassis ground. Prerequisite for this is that the HV voltage is ≥ 100 V (*Voltage: HV_System*) and the existing total insulation resistance *R_iso_original* is ≤ 5 MΩ. As soon as the percentage share of the smaller voltage component falls below the configured threshold value, the corresponding alarm bit (*Status: Warnings_and_Alarms, bit 7*) is set. When the threshold value + 5 % hysteresis is exceeded again, the set alarm bit is deleted automatically (*prerequisite: Self-holding Alarm: Activation = 0xFC*).

Undervoltage error

When the function (*Unbalance: Threshold_Undervoltage > 0*) is activated, the ISOMETER® monitors the HV-system voltage (*Voltage: HV_System*). If the HV-system voltage falls below the configured threshold value, the corresponding alarm bit (*Status: Warnings_and_Alarms, bit 8*) is set. When the threshold value + 5 % hysteresis is exceeded again, the set alarm bit is deleted automatically (*prerequisite: Self-holding Alarm: Activation = 0xFC*).

System condition unstable (fast start measurement)

An active alarm bit (*Status: Warnings_and_Alarms, bit 9*) signals an unstable HV-system condition with respect to the insulation resistance (see chapter "Fast start measurement", page 13").

"Earth" disconnecter open

The device signals an alarm (*Status: Warnings_and_Alarms, bit 10*) as soon as the disconnecter for the chassis-ground connection is open, as no insulation measurement can be carried out with this condition. As soon as the disconnecter has been closed again, the corresponding alarm bit is deleted (*prerequisite: Self-holding Alarm: Activation = 0xFC*).

4.10.3 Status output OK_{HS}

The status output is designed as an open collector topology and connects to terminal 15, when no alarm is active (*Status: Warnings_and_Alarms = 0*). As soon as at least one alarm is active, the internal output transistor locks so that the external pull-down resistor (see chapter "Wiring", page 25) pulls the output to the terminal 31 potential.

4.11 Parameterisation

The following parameters are available starting with firmware version D720V1.01 and can be changed as required by sending a corresponding CAN command:

4.11.1 Cycle time periodic messages

Bender-Standard	J1939	Cycle time (Default)
IMD_Info_General	PGN_Info_General	100 ms
IMD_Info_IsolationDetail	PGN_Info_IsolationDetail	0 (deactivated)
IMD_Info_Voltage	PGN_info_Voltage	0 (deactivated)
IMD_Info_IT-System	PGN_Info_IT-System	0 (deactivated)

A change in the cycle time is implemented immediately without restarting the device.

4.11.2 CAN-ID

Bender-Standard	Default
Request	0x22
Response	0x23
IMD_Info_General	0x37
IMD_Info_IsolationDetail	0x38
IMD_Info_Voltage	0x39
IMD_Info_IT-System	0x3A

Each message must have a unique ID. The ISOMETER® also has a fallback request CAN-ID 0xFF, which cannot be changed and to which the device always responds. This ID must not be used in a system with multiple ISOMETER® devices. If a changed request ID is no longer known, the unique ID is used to still be able to address the device. A changed CAN-ID is only active after the device has been restarted.

4.11.3 Product Group Number (PGN)

J1939	Default
PGN_Info_General	0xFF01
PGN_Info_IsolationDetail	0xFF02
PGN_Info_Voltage	0xFF03
PGN_Info_IT-System	0xFF04

Each PGN must have a unique ID. When sending a request with the CAN ID 0x18EAFF17 and the content 0xFA 0xFF, the device responds once with all PGN_Info_xx messages. The response messages contains both the respective PGN and the source address of the device. This function should only be used if one or more PGNs have been changed but the value is no longer known. It must not be used in a system with multiple ISOMETER® devices. A changed PGN is only active after the device has been restarted.

4.11.4 Baud rate

The ISOMETER® supports the following baud rates (Bender-Standard / J1939):

- 1 Mbit/s
- 800 kBit/s
- 666 kBit/s
- 500 kBit/s
- 250 kBit/s
- 125 kBit/s

A changed baud rate is only active after the device has been restarted.

4.11.5 Source address

For the J1939 protocol, the device's own source address can be set individually. A change to this parameter is only active after the device has been restarted.

4.11.6 Isolnit

A change to the Isolnit parameter is supported by both communication protocols (Bender-Standard / J1939) (default: 0x000 = 0 k Ω).

This parameter is used in profiles without a quick start function to initialise the internal statistics filter. When initialised with 0 k Ω (default), the device starts with an isolation fault and must first perform a "clearance measurement". Several individual measurements are carried out to replace the internal statistics filter with real measured values.

If the internal statistics filter is initialised with 50 M Ω , for example, the device first starts in an error-free state. Any isolation error that may be present must first be determined by several individual measurements.

The startup behaviour of the device is application-dependent and can be adjusted accordingly by changing this parameter. A change to this parameter is only active after the device has been restarted.

5 Dimensions and mounting

Dimensions

Dimension diagram

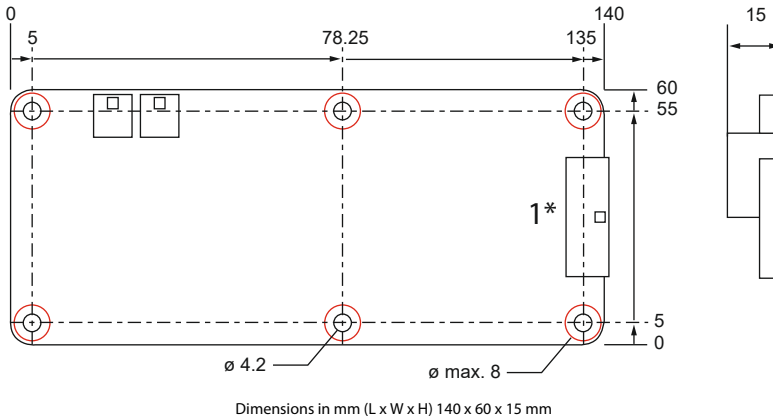

1* LV: protrudes 1 mm from the printed circuit board edge

i Red markings: fastening positions

Mounting

i Mounting and connector kits are not part of the scope of delivery (see chapter ordering information "Accessories", page 38).

Fastening

- Mounting direction: any, deflection see "Tabular data", page 33, Other
- Metal bolts with washers between bolt head and printed circuit board: 6 x M 4
- Tightening torque for the bolts: max. 4 Nm
- Pressure exerted on the printed circuit board at the fastening areas: max. 10 Nm



ADVICE

The washers must be positioned within the gold-plated copper areas designated as fastening areas. This ensures the minimum insulation spacing of 12 mm to other parts.



ADVICE

If the device is mounted on an electrically conductive mounting plate, a minimum height of 14 mm must be observed.

6 Wiring

Wiring diagram

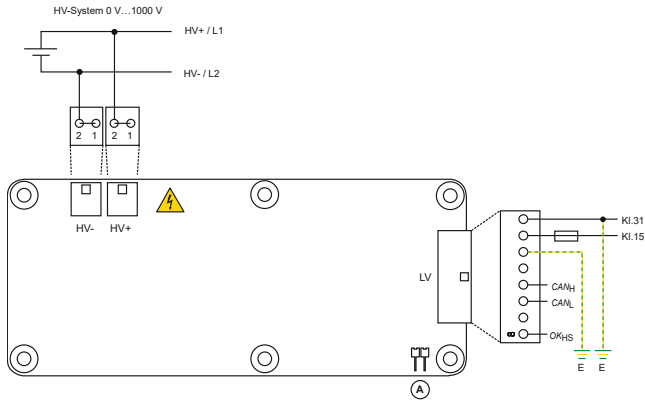

Connector*	Pin no.	Description
HV+	1	Mains voltage (HV+ / L1)
	2	
HV-	1	Mains voltage (HV- / L2)
	2	
LV	1	Supply voltage - (terminal 31)
	2	Supply voltage + (terminal 15)
	3	Earth connection (E) ¹
	4	n.c.
	5	CAN-High
	6	CAN-Low
	7	n.c.
	8	Status output (high side) (OK _{HS}) ²
A	Jumper CAN terminating resistor 120 Ω ³	

¹ Pins 1 and 3 must be on the same potential for fault-free operation.

² The electrical design of the status output is an open-collector topology, which requires a pull-down resistor against terminal 31 for a defined output signal. Here a 2k2 resistor with a power rating of at least 1 W is recommended.

³ The ISOMETER® furnished with an onboard CAN-bus termination with 120 Ω, which can be activated by plugging a jumper (for a recommendation see chapter "Tabular data", page 33) to plug connector A.

* For details on the connectors required to connect to the HV system as well as to the supply voltage refer to chapter "Ordering information", page 37.

For a functioning connection detection of LV pin 3 to chassis ground, the connection of LV pin 1 must also be connected to chassis ground.

7 Commissioning

Once the ISOMETER® has been mounted and connected, the supply voltage and the HV system must be connected.

It can be checked for proper functioning in the following manner:

For appropriate functionality of the CAN-bus interface, a correctly installed termination is necessary. After the supply voltage has been switched on, the device automatically sends the message *IMD_Info_General* at 100 ms intervals. Provided that the device has been configured correctly (e. g. parameter *Isolation: Threshold_Warning*, *Isolation: Threshold_Error*, etc.), and it is in status: *Device Activity = 0xFE*, and at least 12 individual measurements have been performed, an alarm should no longer be active (*Status: Warnings and Alarms*).

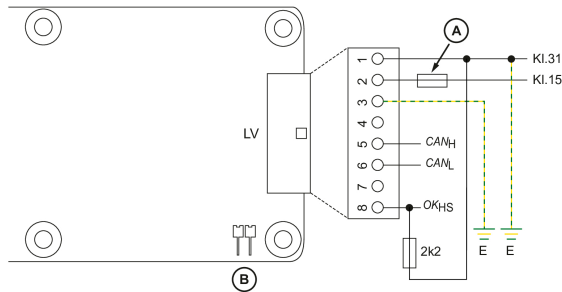

- A Back-up fuse
- B Plug in jumper for activation of 120 Ω termination

8 Operation

8.1 R_iso_corrected / R_iso_original

The insulation resistance measured value $R_{iso_original}$ is the insulation resistance (raw value) actually measured by the device. In accordance with automotive standard LV 123, a measured insulation resistance must never be higher than the actually present insulation fault. For this reason the tolerance* applicable in each case is subtracted from the measured value $R_{iso_original}$, and the measured value $R_{iso_corrected}$ is output additionally. The measured value $R_{iso_corrected}$ is therefore always lower than $R_{iso_original}$.

In the standard configuration, the measured value $R_{iso_corrected}$ is output in the message "IMD_Info_General".

With the ISOMETER® users can additionally read out the measured insulation value $R_{iso_original}$ by sending the command "Isolation: R_iso_original". The message "IMD_Info_Isolation-Detail" also contains this measured value. In the standard configuration this message is not sent automatically. In a customised device variant this can be adapted accordingly.



ADVICE

The evaluation monitoring of the response values (Error, Warning) is always based on the measured value $R_{iso_corrected}$.



* Depending on the measuring range, there are different tolerances, for further information see chapter "Tabular data", page 33.

8.2 Interfaces

8.2.1 Status output OK_{HS}

All device variants have an OK_{HS} output with the same function (see chapter "Status output OK_{HS}", page 21). The HV system can be monitored very easily with the aid of this interface. A precondition for this is that the device parameters (e. g. Threshold Error / Warning) have been adapted accordingly to the specific HV system to be monitored. Proper functioning of this interface can be checked by performing the offline and communication self test manually.

8.2.2 High-Speed CAN

As an alternative to the digital output, a high-speed CAN interface is available for communication. Some measured values, such as the insulation resistance, are already transmitted periodically in the factory setting of the device. Further measured values can be read out manually when needed. No acknowledgement is given for a write command that changes a parameter. Users therefore need to check manually by reading out the parameter concerned to check that a change has been made correctly. An invalid write command, however, is signalled by a corresponding error message (for further information see the CAN specifications, chapter "IMD Request" or "PGN Request"). When a parameter is changed, care shall be taken that the write lock is not activated (Status: Lock). To prevent changing a parameter accidentally, resetting the write lock manually after a parameter has been reprogrammed is recommended. The following control commands are independent of the write lock and can be sent at any time:

- Self-holding Iso-Alarm: *Reset_Alarm*
- Self-test: *Trigger_self_test*
- Earthlift: *Status*

i For internal diagnostic purposes, we reserve the right to use the following addresses:

- 0x400 and 0x400 + diagnostic address (default: 0x401)
- 0x500 and 0x500 + diagnostic address (default: 0x501)

If a message is sent to one of these reserved addresses, the device may respond with a reply to 0x410 or 0x510.

If cyclic communication with these reserved addresses is carried out at very short intervals (e.g. every 50 ms), this can result in an overload of the internal communication. As a result, the device may enter an error state and generate an error message. Cyclic communication with these addresses must therefore be avoided at all costs.

8.3 Insulation measurement

When monitoring the insulation resistance of an HV system the following must be taken into consideration:

Selection of the correct response value (Isolation: Threshold_Error, Isolation: Threshold_warning)

In accordance with standard LV 123, an insulation resistance $> 500 \Omega / V$ is considered to be not dangerous. An insulation fault is correspondingly present starting with an insulation resistance $< 100 \Omega / V$. The response values in the standard configuration (*Error, Warning*) are designed for a 1000 V HV system and, if necessary, can be reconfigured and adapted correspondingly to the respective HV system.

i The device with article no. B91068200 can already be set to specific customised default parameters at the factory. For further information, see customer configuration under "Ordering information", page 37.

Evaluation of Status: Warnings and Alarms

Specific alarm messages signal that the insulation measured value is no longer reliable even though the measured value may be higher than the set alarm threshold values (*Error, Warning*). One example for this is a faulty connection to chassis ground (*Status: Warnings_and_Alarms, bit 4*). Monitoring the status of the alarm bits continuously and reacting to imminent alarms accordingly is recommended (see chapter "Maintenance and trouble-shooting", page 30).

Quality of the insulation resistance measured value

For every insulation resistance measured value there is also a quality information (*Isolation: Quality*), which reflects the reliability of the measured resistance value. In a fault-free HV system (e. g. no voltage fluctuations) the quality should always be between 90 % and 100 %. In a faulty HV system it may occur that internal individual measured values have lower reliability. When such measured values are incorporated into the internal statistical evaluation, also the quality of the calculated measured value is reduced correspondingly. Therefore also the quality value should be monitored continuously, and if it falls below an individual limit value designed for the respective HV system, users shall react accordingly (see chapter "Maintenance and trouble-shooting", page 30).

8.4 Checking the connection of the device

That the ISOMETER® is connected correctly to the HV system is a prerequisite for the measurement of the insulation resistance value. In the standard configuration the device automatically performs an "offline self test" every hour which checks for proper functioning of this connection.



ADVICE

The first automatic check does not take place after a cold start / power cycle, but when the duration of the configured period has expired (default: 1 h). However, users can also perform the test manually (*Self test: Trigger_self_test*). Here it must be taken into account that the self test can only be carried out when the device is in *R_iso_status = 0xFE*.

The selection of the connection cable used is decisive for a properly functioning connection. For information on validated cable types and cable lengths recommended by Bender, see chapter “Tabular data”, page 33, HV connection.

8.5 Profile selection

The active measurement profile can be changed at any time during the insulation measurement. Every measurement profile has specific properties with the concomitant advantages and disadvantages for the insulation measurement (see chapter “Measurement profiles”, page 16). Low quality of the insulation resistance measured value is an indicator that the measurement is disturbed / adversely affected. In such a case users can switch to the profile *Disturbed*. This profile is more robust with respect to varying HV voltages, however it also means longer measurement times.

In light of the many factors influencing the HV system, a general recommendation for the profile to be selected or for changing the profile cannot be given.

9 Maintenance and trouble-shooting

9.1 Unsafe to start is always active

If the fast start measurement always signals an unsafe condition (*true*), the following issues may be the cause:

1. The HV system has a lower insulation resistance than twice the configured alarm threshold value "Warning" (*Isolation: Threshold_Warning*).
Countermeasure:
Check the insulation resistance value during normal operation and, if necessary, adapt the threshold value accordingly.
2. One of the pre-conditions for a fast start measurement is not met, and as a result the fast start measurement is aborted (see chapter "Fast start measurement", page 13).
Countermeasure:
Adjust the parameters *Isolation: Threshold_first_reference_estimation* and *Isolation: Pre_estimation_max_difference* to the HV system to be monitored.

Which of the two values needs to be adjusted depends on the voltage present in the HV system. If the residual voltage in the HV system is constant (e. g. residual charge in the DC link capacitor), then the parameter *Threshold_first_reference_estimation* must be raised accordingly. Adapting this parameter does not significantly influence the accuracy of the measured insulation resistance value during the fast start measurement. In case there is a declining HV voltage in the HV system (e. g. discharging of the DC link capacitor) both parameters must be adapted accordingly to the HV system. Here it must be taken into account that adapting the parameter *Pre_estimation_max_difference* adversely affects the accuracy of the measured insulation resistance value during the fast start measurement. In this case it might make sense to raise the threshold value *Isolation: Threshold_Warning* somewhat to counteract the increased inaccuracy accordingly.

3. In the event of a restart during an insulation measurement, it may be the case that the system leakage capacitances are partially charged. These then might have to be charged in the opposite direction during a restart.
Countermeasure:
In as far as possible, at the end of a measurement a restart of the device should be performed. In this case the system leakage capacitances are charged in a defined manner so that the fast start is not likely to be aborted. As an alternative, the behaviour can be improved by adjusting the two parameters described above.

9.2 Insulation measurement

Insulation fault after a restart

If the fast start measurement cannot be performed and is therefore aborted, the set initialisation value $0\text{ k}\Omega$ is stored in the internal memory, which explains the displayed insulation measured value. I. e. the device starts in a fault condition and first needs to perform a "clearance measurement", which requires several individual measurements. For an estimate of the time required for this, the formula from chapter "Insulation resistance measurement", page 11 can be used.

Countermeasure:

1. The fast start measurement must be adapted so that it runs properly and the vehicle can be started.
2. If the ISOMETER® starts with a high-resistance initialisation (e. g $10\text{ M}\Omega$), the customised profile must be set to a high-resistance initial value.

Starting with firmware version D720V1.01, it is possible to adjust the initial value using a CAN command (index 0x7F).

**ADVICE**

Please note that the presence of an insulation fault in the system can then be detected only later and the vehicle has then already started off. When a customised profile is needed, Customer Service (see chapter "Service and Support", page 5) must be contacted.

3. The "Service" profile can be used to shorten the duration of the start phase until an insulation resistance measured value is available. In contrast to the standard profile, this profile does not perform a statistical filtering and outputs every individual measured value.

**ADVICE**

Using the "Service" profile for the "normal" insulation measurement during driving is not recommended. As there is no statistical filtering, measured values may fluctuate a lot and may no longer meet the accuracy requirements.

Measured insulation values always lower than actual values in the system

- Due to the measuring principle, the measured value $R_{iso_corrected}$ is always lower than the actual insulation fault and can only in certain cases help to explain the observed behaviour (see chapter "R_{iso_corrected} / R_{iso_original}", page 27).

Countermeasure:

For a comparison, the raw measured value, from which no tolerance is subtracted, ($R_{iso_original}$) can be read out (*Isolation: R_{iso_original}*).

- Permanently too small insulation resistance measured values may also be attributable to a system leakage capacitance in the HV system that is too high. The "Standard" and the "Standard with fast startup" profiles are designed for a maximum system leakage capacitance of $\leq 5 \mu\text{F}$.

Countermeasure:

The overall system leakage capacitance in the HV system is determined by correspondingly reading out the measured system leakage capacitance (*Capacity: Measured_value*). If the measured system leakage capacitance is $> 5 \mu\text{F}$, users should, as a rule, select the profiles for high capacitances, i. e. the "High Capacity" and "High Capacity with fast startup" profiles.

**ADVICE**

When these profiles are used, the measuring time becomes longer (see chapter "Available measurement profiles", page 16).

10 Technical data

10.1 Factory settings

Sending the CAN command *Status: Factory_reset = 1* resets all parameters to the factory settings. This requires that the device function “write enable parameter” is active (*Status: Lock = 0xFC*).



ADVICE

For all the factory settings to become active, a power cycle (reset) must be carried out.

Name	Index	Default value
Unbalance: Threshold	0x2E	0 (Unbalance alarm deactivated)
Self holding alarm: Activation	0x30	0xFC (automatic alarm reset)
Isolation: Active_Profile	0x38	1 (Standard with fast startup)
Isolation: Power_On_Profile	0x3A	1 (Standard with fast startup)
Isolation: Threshold_Error	0x46	100 [kΩ]
Isolation: Threshold_Timeout_Measurement	0x48	60 [s]
Isolation: Threshold_Warning	0x4C	500 [kΩ]
Self test: Period	0x58	360 [10 s] 1 h
Voltage: Mode	0x64	0xFE (DC)
Voltage: Threshold_Undervoltage	0x66	0 (deactivated)
Status: Lock	0x6A	0xFC (write enable parameter)
Earthlift: Status	0x70	0xFC (earth disconnecter closed)
Isolation: Threshold_first_reference_estimation	0x72	100 [V]
Isolation: Pre_estimation_max_difference	0x74	200 [0.01 V]

The following parameters are available starting with firmware version ≥ D720V1.01:

Name	Index	Default value
Interface: PGN (J1939)	0x77	PGN_Info_General : 0x01 PGN_Info_IsolationDetail: 0x02 PGN_Info_Voltage: 0x03 PGN_Info_IT-System: 0x04
Bender-Standard	0x77	Request: 0x22 Response: 0x23 IMD_Info_General: 0x37 IMD_Info_IsolationDetail : 0x38 IMD_Info_Voltage: 0x38 IMD_Info_IT-System: 0x3A
Interface: Periodic cycle time	0x79	PGN/IMD_Info_General : 0x01 PGM/IMD_Info_IsolationDetail: 0x00 (deactivated) PGM/IMD_Info_Voltage: 0x00 (deactivated) PGM/IMD_Info_IT-System: 0x00 (deactivated)

10.2 Tabular data

Insulation coordination acc. to IEC 60664-1

Protective separation (reinforced insulation)	between (L1/L2) – (terminal 31, terminal 15, E, CAN _H , CAN _L , OK _{HS})
Rated impulse voltage	6000 V
Overvoltage category	II
Voltage test	DC 4200 V/ 1 min
Pollution degree	2

Supply / monitored IT system

Supply voltage U_s	DC 12...24 V
Tolerance Supply voltage U_s	-17...+50 %
Self consumption, no load at output	≤0.55 W
Max. operating current I_s	300 mA
HV voltage range (L1/L2) U_n	DC 0...1000 V AC 0...480 V _{RMS} (f=50/60Hz)
Tolerance U_n	+10 %
Recommended back-up-fuse	M 630 mA

Response values

Response value R_{an}	30 k...2 MΩ
Response value hysteresis (DCP)	25 %
Undervoltage detection	DC 0...1000 V Default setting: 0 V (inactive)
Undervoltage detection hysteresis	5 %

Measuring range

R_iso_corrected	0...40.5 MΩ
R_iso_original	0...50 MΩ
Insulation: R_iso_neg*	0...50 MΩ
Insulation: R_iso_pos*	0...50 MΩ
Voltage: HV system voltage measurement	DC 0...1000 V AC 0...480 V _{RMS}
Tolerance Voltage: HV system voltage measurement	±5 % ± 2 V
Capacity C_e : Measured_Value	0...10 μF
Unbalance U_n (Prerequisite: DC ≥ 100 V, R_iso ≤ 5 MΩ)	0...100 %
Tolerance Unbalance	±5 %

Relative uncertainty of the estimated measured values of the fast start measurement: R_iso_status = 0xFC)

0...-100 %

Tolerance "R_iso_corrected" (R_iso_status = 0xFD)	Measuring range	Abs. fault 0...-50 kΩ Rel. fault
	0...50 kΩ	0...-48 %
	50 kΩ...1.2 MΩ	0...-48 % to 0...-76 %
	1.2...5 MΩ	0...-76 %
	5...10 MΩ	not specified
	> 10 MΩ	not specified

Tolerance "R_iso_corrected" (R_iso_status = 0xFE)	Measuring range	Abs. fault 0...-50 kΩ Rel. fault
	0...50 kΩ	0...-24 %
	50 kΩ...1.2 MΩ	0...-24 % to 0...-38 %
	1.2...5 MΩ	0...-38 %
	5...10 MΩ	not specified
	> 10 MΩ	not specified

* Available from an HV voltage > 100 V

Time response

Enabling time t_{start} (OK_{HS} ; fast start measurement)	≤ 5 s ($C_e \leq 2$ μF)
Response time t_{an} (OK_{HS}) as per LV 123 (100...500 Ω/V, 2 μF (profiles: Standard/ Standard with fast startup)	≤ 30 s
Switch-off time t_{ab} (OK_{HS} ; DCP)/ insulation fault (100...500 Ω/V) until R_iso ≥ 10 MΩ, $C_e \leq 1$ μF	Profil standard ≤ 55 s Profil high capacity ≤ 60 s Profil disturbed ≤ 115 s Profil service ≤ 36 s
Online self test	≤ 1 s
Offline self test with output test (OK_{HS})	≤ 5 s

Measuring circuit

System leakage capacitance C_e max.	Standard profile ≤ 5 μF High capacity (capacitance) profile ≤ 10 μF Disturbed profile ≤ 10 μF
Measuring voltage U_M	± 35 V ± 2 V
Measuring current I_M at $R_F = 0$ kΩ	$\leq \pm 30$ μA
DC internal resistance R_i	1.2 MΩ ± 2 %

Status output OK_{HS}

OK_{HS} (High-Side driver) high U_s^*	$\geq U_s - 2$ V
OK_{HS} (High-Side driver) low U_s^*	$\leq 0,2$ V
Permissible output current max.	80 mA

* With correctly connected pull-down resistor (2k2 Ω)

CAN interface

Data transmission rate	125, 250, 500, 666, 800, 1000 kBaud
Terminating resistor	120 Ω*

* via jumper: Recommended: Weitronic W+P Products Jumper series 165. Manufacturer ordering no.: 165-101-10-00

EMC

Load-dump protection	≤ 58 V
----------------------	--------

ESD protection

Contact discharge – directly at the terminals	≤ 4 kV
Contact discharge – indirectly via the environment	≤ 4 kV
Air discharge – handling of printed circuit board	≤ 8 kV

HV connection

Cable length, max.	2 m
Cable cross section	AWG 20...24
Validated cable type	AlphaWire 5875

Environment

Operating temperature	-40...+105 °C
Temperature cycle (ISO 16750-4)	Ka
Air humidity (rH)	0...100 %
Altitude	≤ 3000 m

Classification of climatic conditions acc. to IEC 60721

Transport (IEC 60721-3-2)	2K11
Long-time storage (IEC 60721-3-1)	1K21

Classification of mechanical conditions acc. to IEC 60721

Transport (IEC 60721-3-2)	2M4
Long-time storage (IEC 60721-3-1)	1M10

Other

Operating mode	Continuous operation
Flammability class as per	UL 94 V-0
Deflection	max. 1 % of the length or width of the PCB
Coating	Protective paint (ELPEGUARD® SL 1307 FLZ)
Weight	37 g ± 3 g

10.3 Standards and approvals

The ISOMETER® iso175 has been developed in accordance with the following standards and approvals:

- IEC 61010-1
- IEC 60664-1
- IEC 60068-2-6
- IEC 60068-2-14
- IEC 60068-2-27
- IEC 60068-2-64
- ISO 6469-3
- ISO 16750-2
- ISO 16750-3
- ISO 16750-4
- (UN)ECE R10 Rev.6
- SAE J1939-82
- Insulation measurement functions based on: IEC 61557-8

Open-source software

For a list of the open-source software used see our [Website](#).

Cybersecurity

An assessment in accordance with (UN)ECE R155, R156 and ISO/SAE 21434 has been carried out. Further information is documented in the separately available Cybersecurity Case and in the Cybersecurity Safety Manual. The documents are available for download:

<https://www.bender.de/fileadmin/content/Products/m/e/iso175-Cybersecurity-Case.pdf>

<https://www.bender.de/fileadmin/content/Products/m/e/iso175-Cybersecurity-Safety-Manual.pdf>

10.4 Ordering information

Standard variants

Type	Connector type (connection)	Interfaces	Standard-configuration	Art. No.	Manual No.
iso175C-32-SS	TYCO ¹	HS-CAN SAE J1939	Baud rate: 500 kBaud	B91068201	D00415
iso175C-42-SS	Samtec/Molex ²			B91068202	
iso175C-32-SB	TYCO ¹	HS-CAN Bender-Standard	Response value: 100 kΩ (error) 500 kΩ (warning)	B91068203	
iso175C-42-SB	Samtec/Molex ²			B91068204	

¹ HV+ / HV- connections

- Connector: TE Connectivity / AMP
- Tyco-Micro Mate-N-Lok™, 1445022-2

LV connection

- Connector: TE Connectivity / AMP
- Tyco-Micro Mate-N-Lok™, 1445022-8

Crimp contacts, suitable for both connections

- Connector: TE Connectivity / AMP
- Tyco-Micro Mate-N-Lok™ gold, plating B (38 μm), 1-794606-1
- Crimping tool (Tyco): 91501-1 (AWG 20...24)

² HV+ / HV- connections

- Connector: Molex Mini Fit Jr. Housing, 39-01-2025
- Crimp contact: Mini Fit Jr. Contact gold, 39-00-0089, AWG 16
- Crimping tool (Molex): 2002182200

LV connection

- Connector: Samtec Mini Mate Housing, IPD1-08-S-K
- Crimp contact: Samtec Mini Mate gold, CC79R2024-01-L, AWG 20...24
- Crimping tool: 20-30 AWG (Samtec): CAT-HT-179-2030-13

Cable recommendation for proper functioning of the offline self test: AlphaWire (Art. No. 5875)

i CAN configurations (e.g. baud rate and addressing) cannot be changed later. Retrospective modification of these parameters is only available starting with firmware version D720V1.01.

Customized variants*

Type	Connector type (connection)	Interfaces	Customer-configuration	Art. No.	Manual No.
iso175 customized	TYCO (side) or Samtec/Molex (top)	HS-CAN (SAE J1939 or Bender-Standard)	According to customer specifications	B91068200	D00415

* For sales contact data and further information see "<https://www.bender.de/loesungen/emobility/>".

Accessories

Description	Suitable for type	Art. No.
IR155 / iso175 fastening kit	All	B91068500
IR155 / iso175 connection kit (TYCO)	iso175X-32-XX	B91068501
IR155 / iso175 connection kit (Samtec/Molex)	iso175X-42-XX	B91068502

10.5 Revision history

Date	Document version	State / Modification
10/2023	00	New
11/2023	01	Deleted: PWM variants Added: Chapter 10.3: 3 Norms
08/2024	02	Added: Chapter 4.3.1: Note Chapter 5: Dimension diagram $\varnothing 8$ mm Chapter 10.2: Tolerance U_{nr} , Switch-Off time t_{ab} Chapter 10.4: Customized variants
07/2025	03	Added: Notes about firmware version D720V1.01 Chapter 4.7: Change in HV voltage and parallel connection Chapter 4.11: Parameterisation Chapter 10.1: Parameters about firmware version D720V1.01 Chapter 10.2: Tolerances and tabular data about AC



Bender GmbH & Co. KG

Londorfer Straße 65
35305 Grünberg
Germany

Tel.: +49 6401 807-707
emobility@bender.de
www.bender.de

All rights reserved.
Reprinting and duplicating only with
permission of the publisher.



© Bender GmbH & Co. KG, Germany
Subject to change!
The specified standards take into
account the edition valid until 07.2025
unless otherwise indicated.